

Review Packet: Physics



mannequin is sliding

The mannequin weighs 800 N. The person is pushing to the right with a force of 150 N. The coefficient of friction between the mannequin and the floor is 0.25.

x: Fnet
50 N ←

y: Fnet
0

- The mannequin is slowing down.
- The mannequin is speeding up.
- The mannequin's speed is constant.
- The mannequin is slowing down.
- The mannequin is speeding up.
- The mannequin's speed is constant.

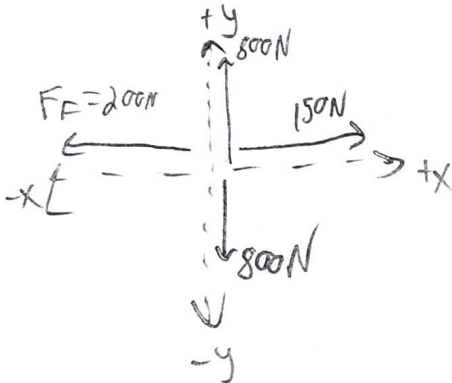

$$F_f = (800\text{ N})(0.25) = 200\text{ N}$$

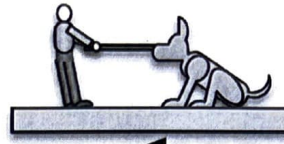

Fido is sliding

x: Fnet
10 N ←

y: Fnet
0

- Fido is slowing down.
- Fido is speeding up.
- Fido's speed is constant.
- Fido is slowing down.
- Fido is speeding up.
- Fido's speed is constant.

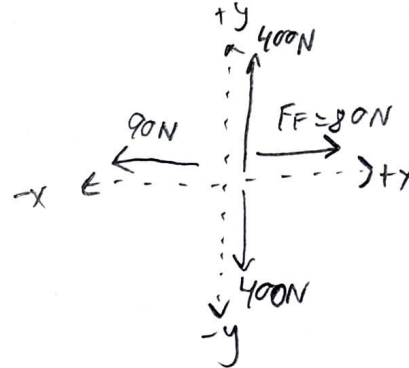

$$F_f = (400\text{ N})(0.2) = 80\text{ N}$$

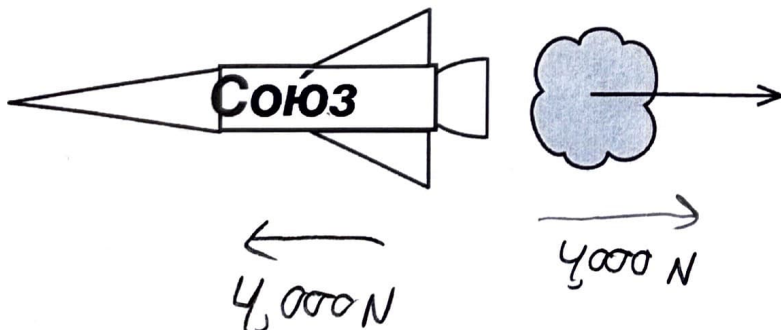

Far from any gravitational influence, the rocket ejects 100kg of gas with a force of 4,000 N to the right. There is no friction in space.

a. What is the acceleration of the cloud?

$$\frac{4,000\text{ N}}{100\text{ kg}} = 40\text{ m/s}^2$$

b. What is the acceleration of the rocket?
(Mass = 8,000 kg)

$$\frac{4,000\text{ N}}{8,000\text{ kg}} = 0.5\text{ m/s}^2$$

Force pairs are equal!

Review Packet: Physics

The Tension force on rope 1 is 700N, the Tension for on rope 2 is 800N and this person weighs 900N. Solve for the Net force in 'x' and 'y'.

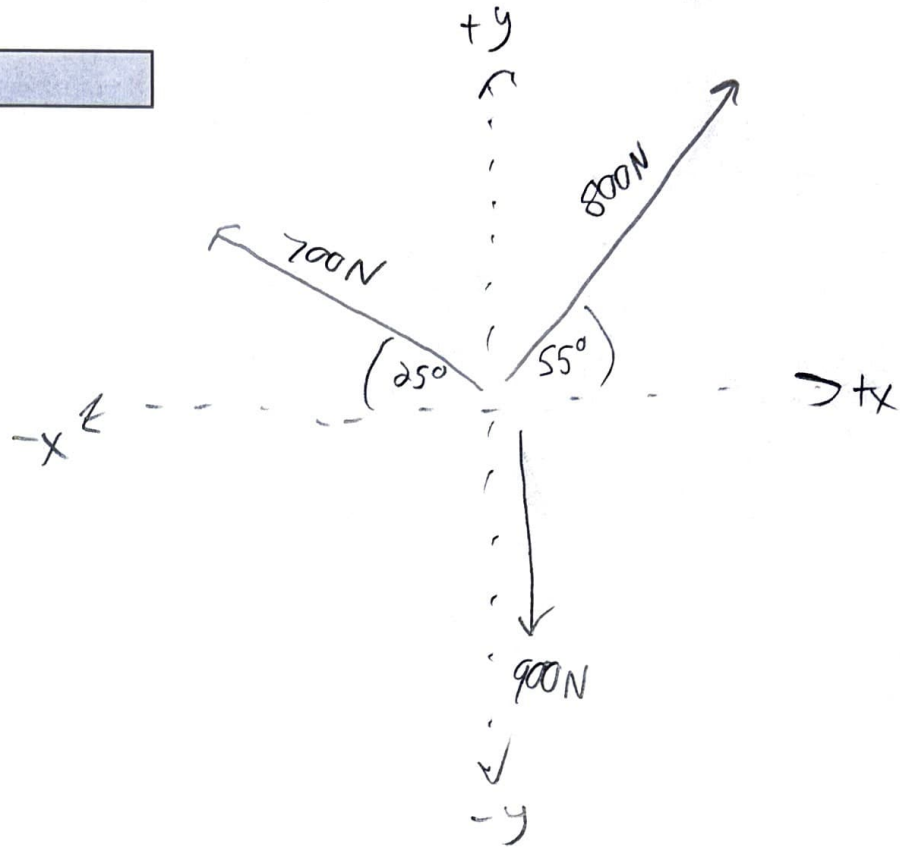
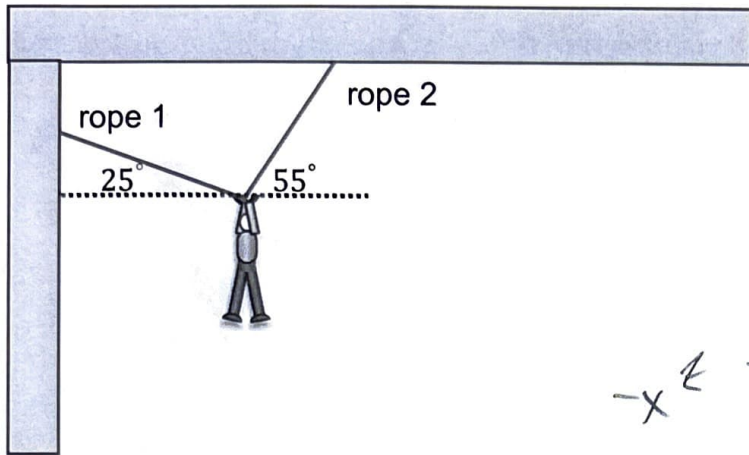

	X	Y
$F_{T,1}$	$(700N) \cos 25 =$ $-634 N$	$(700N) \sin 25 =$ $+296 N$
$F_{T,2}$	$(800N) \cos 55 =$ $+459 N$	$(800N) \sin 55 =$ $+655 N$
F_G	0	-900N
F_{Net}	-175 N	+51 N

Review Packet: Physics

What is the coefficient of friction if this 650 kg car is at rest and staying at rest on this incline?

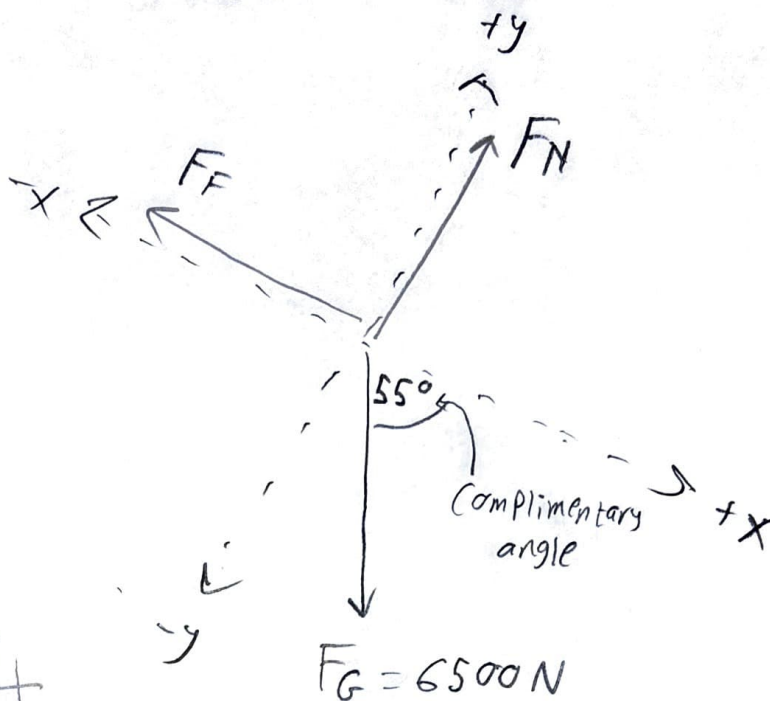
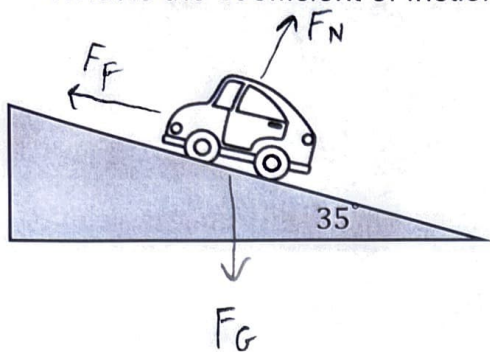

	X	Y
F_N	0	+ F_N
F_F	- F_F	0
F_G	$(6500N) \cos 55$ 3728 N	$(6500N) \sin 55$ 5324 N
F_{Net}	0	0

$$X: 0 = 3728 - F_F$$

$$F_F = 3728 N$$

$$y: 0 = 5324 + F_N$$

$$F_N = 5324 N$$

$$\mu = \frac{F_F}{F_N} = \frac{3728 N}{5324 N} = \underline{0.7}$$

Review Packet: Physics

Dino pushes 50 kg Gina on an old pair of roller skates with a force of 100 N. There is 25 N of friction due to the squeaky old wheels of the skates. They start from a speed of 1 m/s.

- Put the forces on the diagram & find the net force.
- Calculate the speed change factor.
- Fill in the table below up to 3 s.

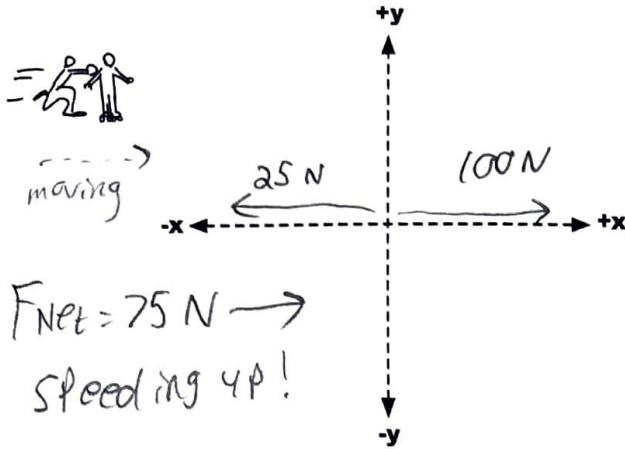

$$\frac{75 \text{ N}}{50 \text{ kg}} = 1.5 \text{ m/s/s}$$

Then after $t = 3$ s, Dino stops pushing, and Gina continues with only the friction force in the x-direction.

- Put the forces on the diagram & find the net force.
- Calculate the speed change factor.
- Fill in the rest of the table.

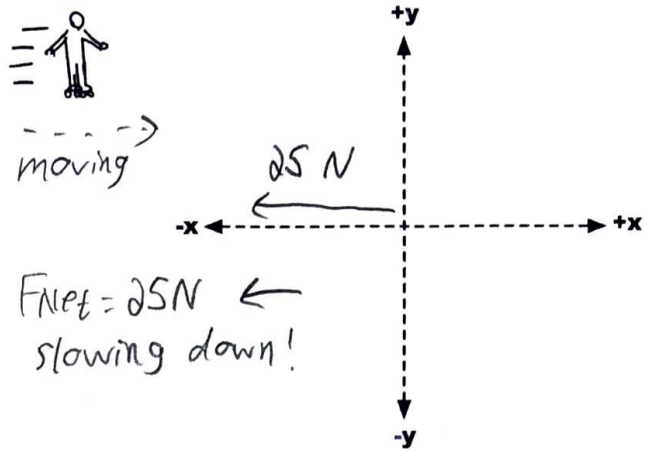

$$\frac{25 \text{ N}}{50 \text{ kg}} = 0.5 \text{ m/s/s}$$

Speed at $t = 0$	Speed at $t = 1$ s	Speed at $t = 2$ s	Speed at $t = 3$ s	Speed at $t = 4$ s	Speed at $t = 5$ s	Speed at $t = 6$ s	Speed at $t = 7$ s
1 m/s	2.5 m/s	4 m/s	5.5 m/s	5 m/s	4.5 m/s	4 m/s	3.5 m/s

TRACK THE FRONT OF THE PERSON'S FOOT

Fill in the boxes and find the acceleration based on the clues given about the person's motion.

$t = 0$ s



Their acceleration is -2 m/s/s.

t (s)	x (m)	v (m/s)
0	-3	
1	4	7
2	9	5
3	12	3

$t = 0$ s

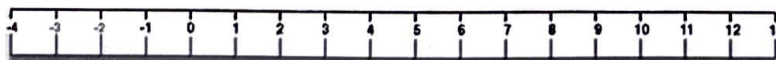

Their acceleration is $+1$ m/s/s.

t (s)	x (m)	v (m/s)
0	11	
1	6	-5
2	2	-4
3	-1	-3

Review Packet: Physics

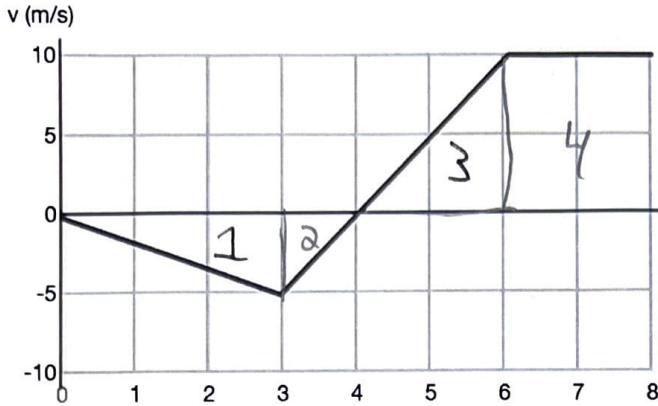

total change in position calculation

① $\frac{1}{2}(5)(3) = -7.5$

② $\frac{1}{2}(5)(1) = -2.5$

③ $\frac{1}{2}(2)(10) = +10$

④ $(10)(2) = +20$

20 meters

from when to when	description (words)	acceleration calculation
0 - 3	speed up moving left	$\frac{\text{rise}}{\text{run}} = \frac{-5}{3} = -1.7 \text{ m/s/s}$
3 - 4	slow down moving left	$\frac{\text{rise}}{\text{run}} = \frac{5}{1} = 5 \text{ m/s/s}$
4 - 6	speed up moving right	$\frac{\text{rise}}{\text{run}} = \frac{10}{2} = 5 \text{ m/s/s}$
6 - 8	constant speed of 10m/s moving right	0

For each pair of situations, sketch out which Force vs. Time graph it would have.



I caught a fastball with a glove.

Vs.

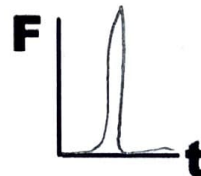

I caught a fastball without a glove.

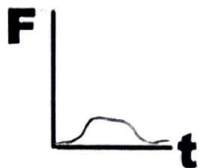

An experienced stunt person lands from a fall.

Vs.

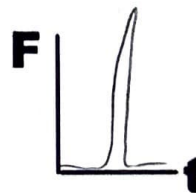

Someone faints and falls.

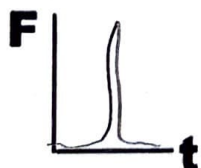

The front end of old cars when crashing.

Vs.

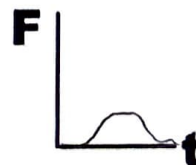

The front end of new cars when crashing.

Review Packet: Physics

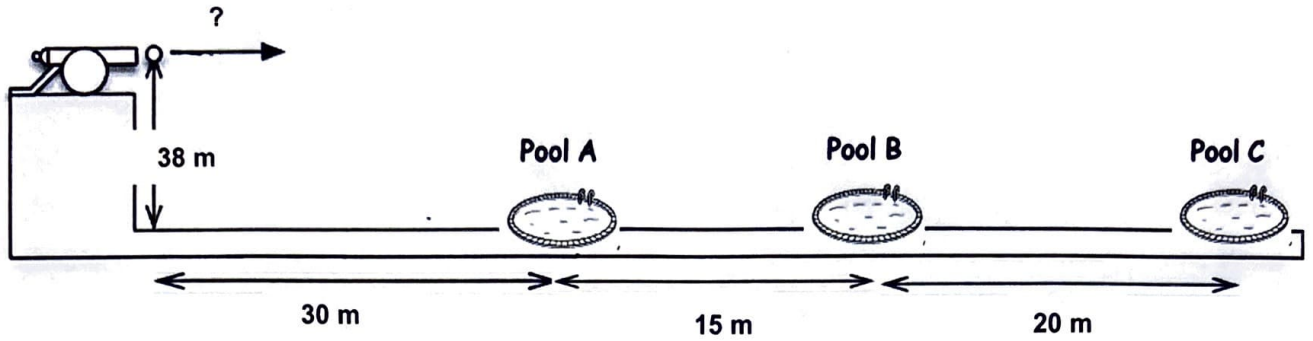

How fast does the cannonball need to be launched to land in...

- Pool A: 10.7 m/s
- Pool B: 16.1 m/s
- Pool C: 23.2 m/s

x	y
$a = 0$	$a = -10$
	$d = -38$
	$v_i = 0$
	$t = ?$

Pool A:

"x" direction:

$$a = 0$$

$$t = 2.8$$

$$d = 30$$

$$v_i = ?$$

Pool B:

"x" direction:

$$a = 0$$

$$t = 2.8$$

$$d = 45$$

$$v_i = ?$$

$$d = v_i t + \frac{1}{2} a t^2$$

$$\downarrow$$

$$-38 = (0)(t) + \frac{1}{2}(-10)t^2$$

$$-38 = -5t^2$$

$$7.6 = t^2$$

$$t = 2.8 \text{ seconds}$$

Pool C:

"x" direction:

$$a = 0 \quad v_i = ?$$

$$t = 2.8$$

$$d = 65$$

$$\text{USE } d = v_i t + \frac{1}{2} a t^2$$

for each!

Review Packet: Physics



The football is thrown from and caught at the same height.

- Resolve the velocity into its components.
- How long was the ball in flight?
- What horizontal distance did the ball travel?
- How high above the start height did the ball get?

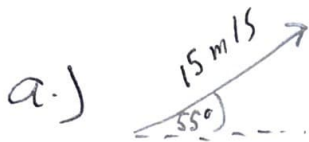

$$V_x = (15 \text{ m/s}) \cos 55 = 8.6 \text{ m/s}$$

$$V_y = (15 \text{ m/s}) \sin 55 = 12.3 \text{ m/s}$$

b.) "V" at peak is zero in "y"

$$V_f = 0$$

$$V_i = 12.3 \text{ m/s}$$

$$a = -10 \text{ m/s}^2$$

$$t = ?$$

$$0 = 12.3 + (-10)t$$

$$t = 1.23 \text{ sec}$$

DOUBLE IT

$$t = 2.46 \text{ seconds}$$

c.) $V_i = 8.6 \text{ m/s}$

$$t = 2.46 \text{ s}$$

$$a = 0$$

$$d = ?$$

$$d = (8.6)(2.46) = 21.2 \text{ meters}$$

d.) $V_f = 0$

$$V_i = 12.3 \text{ m/s}$$

$$a = -10 \text{ m/s}^2$$

$$d = ?$$

$$V_f^2 = V_i^2 + 2ad$$

$$0^2 = 12.3^2 + 2(-10)d$$

$$d = 7.6 \text{ meters}$$

Review Packet: Physics

Rank the planets orbits from MOST elliptical to LEAST elliptical!

- Vulcan: Aphelion = 4.1 AU; Perihelion = 3.7 AU
- Naboo: Aphelion = 5.5 AU; Perihelion = 4.9 AU
- Ix: Aphelion = 6.5 AU; Perihelion = 6.2 AU
- Septimus: Aphelion = 8.9 AU; Perihelion = 8.2 AU

Most Elliptical \longrightarrow Least Elliptical

Naboo Vulcan Septimus Ix

$$\text{Vulcan} = \frac{(4.1 - 3.7)}{(4.1 + 3.7)} = \frac{0.4}{7.8} = 0.051$$

$$\text{Ix} = \frac{(6.5 - 6.2)}{(6.5 + 6.2)} = \frac{0.3}{12.7} = 0.024$$

$$\text{Naboo} = \frac{(5.5 - 4.9)}{(5.5 + 4.9)} = \frac{0.6}{10.4} = 0.058$$

$$\text{Septimus} = \frac{(8.9 - 8.2)}{(8.9 + 8.2)} = \frac{0.7}{17.1} = 0.041$$

Figure out which planet orbits which star based on the semimajor axis and orbital period.

Planet	Semimajor Axis	Orbital Period
Marklar	4 AU	2 Earth Years
Naboo	2 AU	4 Earth Years
Salusa Secundus	5 AU	5 Earth Years
LV-426	10 AU	25 Earth Years
Terminus	8 AU	4 Earth Years

$$\frac{a^3}{T^2} = \text{mass in solar masses}$$

Star	Planet?
16 Solar Masses	Marklar
1.6 Solar Masses	LV-426
32 Solar Masses	Terminus
5 Solar Masses	S.S.
0.5 Solar Masses	Naboo

$$\text{Marklar: } \frac{4^3}{2^2} = \frac{64}{4} = \underline{\underline{16}}$$

$$\text{Naboo: } \frac{2^3}{4^2} = \frac{8}{16} = \underline{\underline{0.5}}$$

$$\text{Terminus: } \frac{8^3}{4^2} = \frac{512}{16} = \underline{\underline{32}}$$

$$\text{S.S.: } \frac{5^3}{5^2} = \frac{125}{25} = \underline{\underline{5}}$$

$$\text{LV-426: } \frac{10^3}{25^2} = \frac{1000}{625} = \underline{\underline{1.6}}$$

Review Packet: Physics

Fill in the table below based on the illustration. Include the right units (Image not to scale)

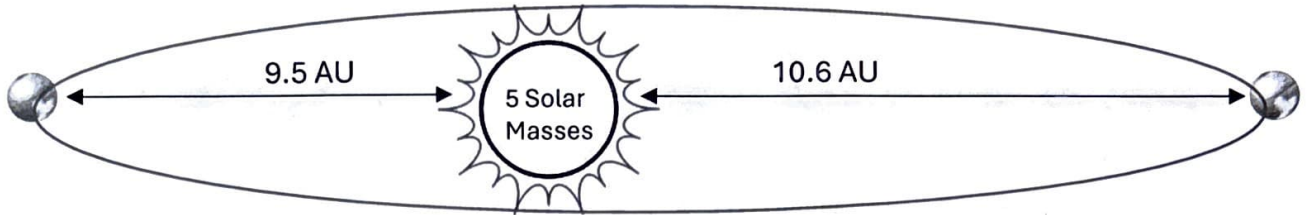

Aphelion:	10.6 AU
Perihelion:	9.5 AU
Major Axis:	$10.6 + 9.5 = 20.1 \text{ AU}$
Semimajor Axis:	$\frac{20.1 \text{ AU}}{2} = 10.05 \text{ AU}$
Eccentricity:	$\frac{(10.6 - 9.5)}{(10.6 + 9.5)} = \frac{1.1}{20.1} = 0.055$
Orbital Period:	14.2 Earth years

$$5 = \frac{(10.05)^3}{T^2}$$

$$(5)(T^2) = (10.05^3)$$

$$T^2 = \frac{(10.05^3)}{5}$$

$$T^2 = 203$$

$$T = 14.2$$

Review Packet: Physics

Fill in the blanks. Word bank is below.

- The region in space where no light can escape the immense curvature of spacetime is called the Event Horizon
- Spacetime curves in the presence of mass and is the way that gravity propagates throughout space.
- Time Dilation is the phenomenon where time ticks slower as the curvature of spacetime increases and time ticks at different rates for observers depending on their speed relative to each other.
- The singularity is the point at the center of a black hole where all the mass is compressed into an infinitely small point and where all the matter that falls into the black hole will inevitably end up.
- The Accretion Disk is a disk of super-hot gas and dust orbiting the black hole at a significant fraction of the speed of light
- Gravitational Lensing is when light bends around objects with large mass like galaxy clusters and black holes.
- The Photon sphere is the region in which light can go into an unstable orbit, around the black hole.
- General Relativity is our best description of the large-scale structure of the universe.
- The Schwarzschild radius is the radius that an object needs to be compressed to become a black hole.
- Length Contraction is when the apparent length of distances and objects significantly shrinks as they approach near the speed of light.

Word Bank

Time Dilation Gravitational Lensing Photon Sphere Event Horizon Spacetime
Length Contraction Singularity Accretion Disk General Relativity Schwarzschild Radius